

Pressure Relief and Back Pressure Diaphragm Valves

Stocked in 316 S/S, Alloy C, and Alloy 20

ECO VALVE FEATURES

Wetted parts of 316 stainless steel, high nickel Alloy C or Alloy 20.

Topworks isolated from fluid by TFE diaphragm.

Diaphragm "cushioned" in seat area.

Critical parts above the diaphragm are stainless steel or TFE.

Valve seat easily replaceable.

Pressure adjustment spring of high tensile steel.

Simple set pressure adjustment guarded by cast iron cap.

Threaded "weep" hole in cast iron bonnet.

Leak proof operation.

Immediate delivery.

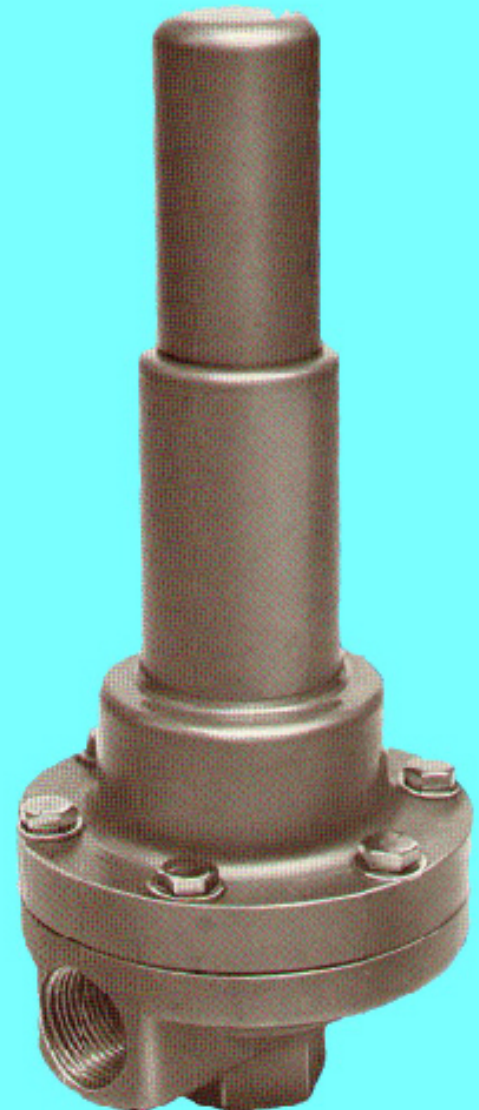

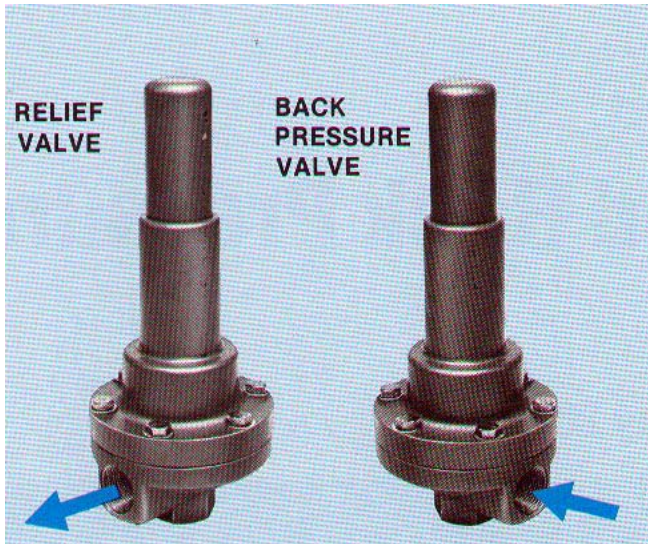

ECO diaphragm relief valves and back pressure valves have been developed specifically to provide long-life and reliable service in systems handling corrosive fluids. While the two valves perform different functions, most components are identical to both units providing advantages in cost, availability and reliability.

ECO valves are supplied with all wetted parts of either 316 stainless steel, high nickel Alloy C or Alloy 20. Lading fluid is confined to the body of both valves by a flexible, chemically-inert TFE diaphragm. Since the pressure adjustment spring is not exposed to the corrosive fluid the choice of spring material is not limited. High-tensile steel wire is used for high reliability and dependable operation at the set pressure over a wide temperature range.

Both valves feature a field-replaceable seat. Poppets and guides are of corrosion resistant stainless steel to minimize the effects of corrosive plant atmospheres. Bonnets and caps are close-grained cast iron and the bonnet is drilled and tapped with a large "weep" hole for an 1/8" NPT connection. All routine servicing can be performed without removing the valve body from the line or breaking the main piping connections.

A single spring covers the entire design pressure range for both valves. Adjustments are made with a standard hex key wrench.

GENERAL SPECIFICATIONS

Characteristic	Relief Valve	Back Pressure Valve
Flow Range	Through 25 gpm (5.7 m ³ /hr)	Through 25 gpm (5.7 m ³ /hr)
Set Pressure Range	10-150 psig (70-1050 kPa)	10-150 psig (70-1050 kPa)
Inlet Port Size	3/4" NPT	3/4" NPT
Inlet Port Location	Bottom	Bottom
Outlet Port Size	3/4" NPT	3/4" NPT
Outlet Port Location	Side	Side
Viscosity Limit	200 cP (1000 SSU) Max	
Temperature Range	-30°F (-35°C) to 250°F (121°C)	
Dry Weight	6 1/2 lbs. (Kg)	
Body Cavity Volume	3 cu. In (50cc)	

RELIEF VALVES

ECO diaphragm relief valves are designed to relieve potentially dangerous overpressures in systems handling corrosive fluids. Although developed specifically for use with ECO's positive displacement pumps, the valves are widely used in a variety of general liquid-relief service where corrosion resistance is of prime importance.

These valves are not intended for gas or vapor service, or for operation as a continuous bypass valve. For bypass service, the ECO back pressure valve is the preferred choice.

ECO rotary positive displacement pumps are not available with built-in relief valves and the diaphragm relief valve, or an equivalent unit, is the preferred method of overpressure protection. Fluid recirculation in a pump with an internal valve can cause rapid heat buildup and increased corrosion due to the temperature rise. Because of this, the outlet of the ECO relief valve should never be piped back to the pump suction. Instead, the valve should be connected to a safe drain, or piped back to the fluid supply vessel. The "weep" hole should also be piped back to the fluid supply vessel or safe drain.

BACK PRESSURE VALVES

ECO back pressure valves provide a preset pressure in the discharge system of pumps handling corrosive fluids. They are particularly useful in metering applications, or other low-flow systems, where a portion of the pump output is bypassed back to the source of supply. In these systems, the valve provides a constant pressure in the discharge line, and flow rate is controlled by a throttling valve in the bypass line.

Back pressure valves are also widely used in vacuum systems. They allow controlled feed from a source at atmospheric pressure to a column under vacuum, and provide a means of pressurizing the seal chamber of an ECO gear pump equipped with a single external seal for vacuum service.

In addition to systems using ECO pumps, these back pressure valves are also useful for other types of pumping equipment. Reciprocating plunger metering pumps, for example, require a discharge pressure higher than the suction pressure in order to operate properly. The ECO back pressure valve provides the necessary differential pressure to enable check valves to operate properly and prevent siphoning. The "weep" hole should be piped to a safe drain.



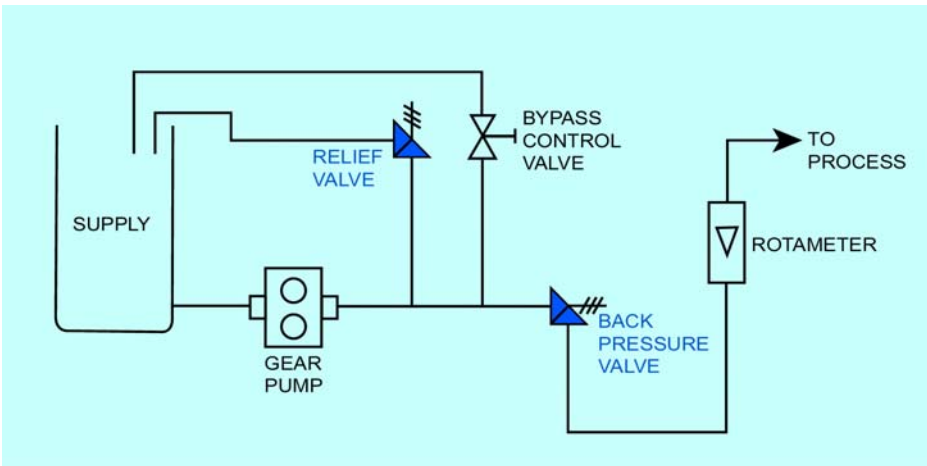

This metering system uses both a back pressure valve and a relief valve for best results. The back pressure valve provides a constant pressure in the discharge line. With this arrangement, flow to the process can be controlled very precisely by adjusting the bypass control valve.

The relief valve, piped as shown here, provides protection for the pump and other system components in the event of an overpressure condition. Output from the relief valve should always be piped back to the supply tank or to a safe drain, and never back to the pump input. The only exception is when service is intermittent, such as in drum transfer.

ECO back pressure valves are widely used in systems supplying feed to a vacuum column from a supply source at atmospheric pressure. The valve presents a constant back pressure to the feed pump, minimizing fluctuations in feed rates due to changing still pressures.

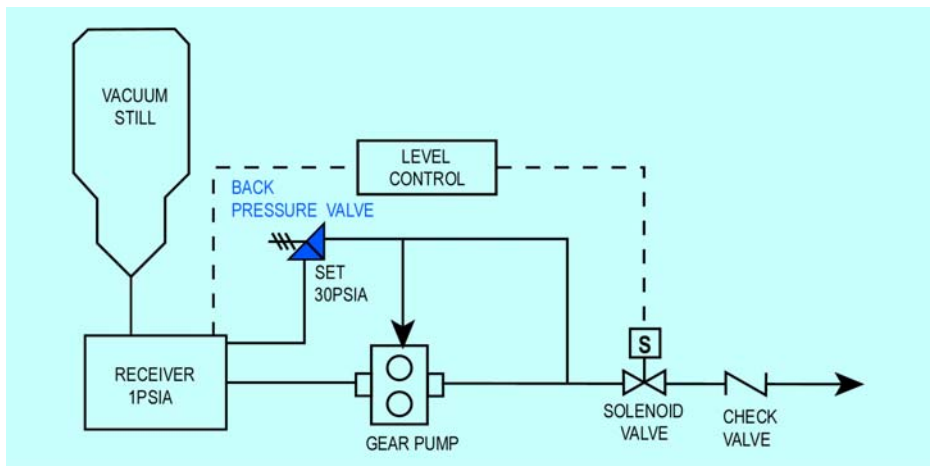
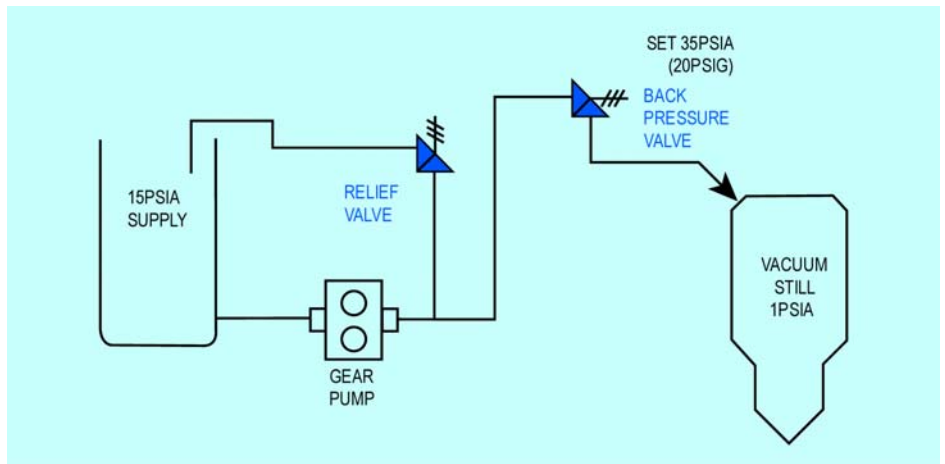

This gear pump system is being used to pump from a receiver while maintaining high vacuum in the system. The pump operates continuously in a recycling loop with a level control signaling when the receiver is to be emptied. The seat pressurization line provides a continuous pressure to the pump's vacuum seal, creating a hydraulic barrier and preventing air entering the pump.

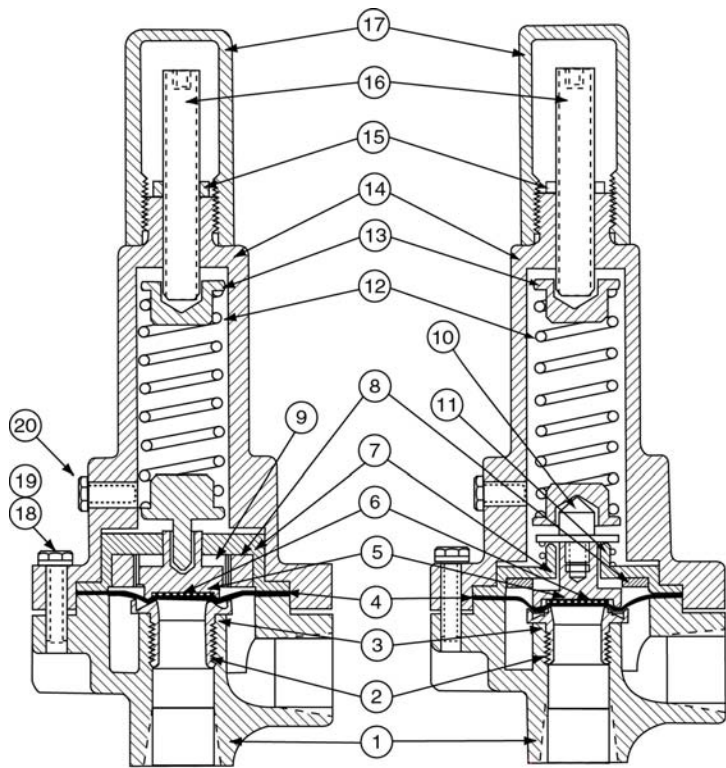

LIQUID RELIEF VALVE

Model VR-6A-1 (316 SS)
 VR-6C-1 (ALLOY C)
 VR-6D-1 (ALLOY 20)

BACK PRESSURE VALVE

Model VBP-6A-1 (316 SS)
 VBP-6C-1 (ALLOY C)
 VBP-6D-1 (ALLOY 20)

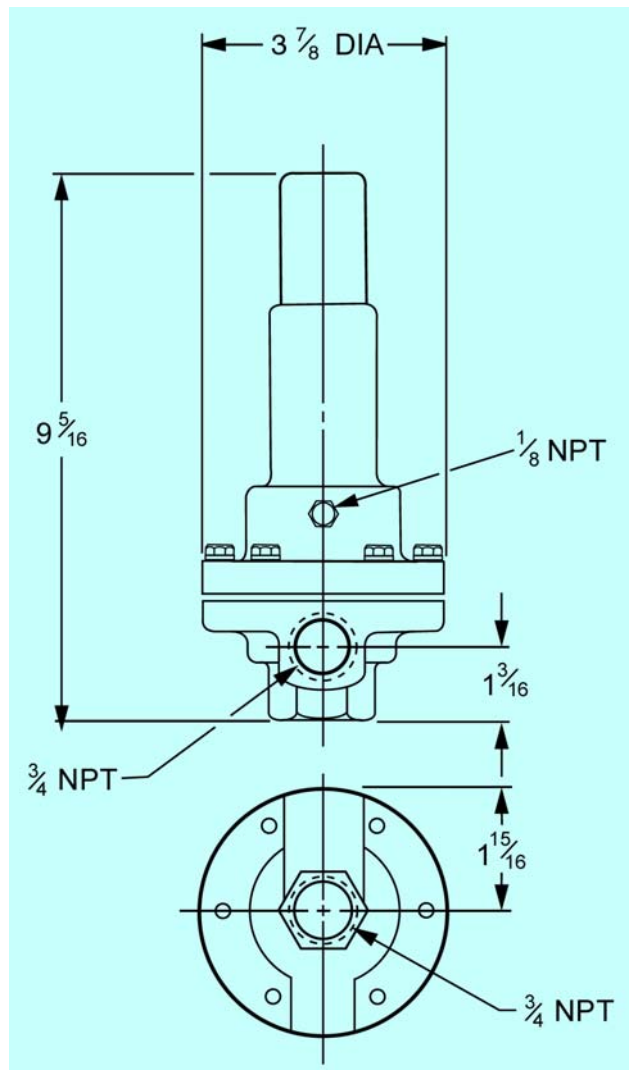

MATERIALS OF CONSTRUCTION

DESCRIPTION	ITEM	BASIC VALUE MATERIAL		
		316 SS	ALLOY C	ALLOY 20
*Body	1	316 SS	ALLOY C	ALLOY 20
*Seat	2	316 SS	ALLOY C	ALLOY 20
*O-ring, Seat	3	TFE	TFE	TFE
Diaphragm	4	TFE	TFE	TFE
Poppet	5	316 SS		
*Insert, Poppet	6	TFE		
Guide	7	18-8 SS		
Insert, Guide	8	TFE		
Strip, Guide	9	TFE (RV only)		
Retainer, Poppet	10	18-8 SS (BPV only)		
Spring, Poppet	11	316 SS (BPV only)		
Spring	12	Steel		
*Retainer, Spring	13	Steel		
*Bonnet	14	Cast Iron		
*Lock Nut	15	Steel		
*Screw, Adjustment	16	Steel		
*Cap	17	Cast Iron		
*Screw	18	18-8 SS		
*Lock Washer	19	18-8 SS		
*Pipe Plug	20	Steel		

*Denotes parts common to both relief and back pressure valves. Parts not shown in color are above the diaphragm and are non-wetted.



PULSAFEEDER
 A Unit of IDEX Corporation



Engineered Pump Operations
 2883 Brighton-Henrietta Town Line Road
 Rochester, New York 14623
 Telephone: (716) 292-8000
 Fax: (716) 424-5619

http://www.pulsa.com – E-mail: pulsa@pulsa.com