

Johnson Pump (UK), versatile in application...



Fresh Organic Soups...

To produce a fresh, organic vegetable soup needs care and even a small amount of love. At Johnson Pump (UK) we know how to handle particulates; we know how to handle florets of cauliflower and broccoli, whole beans and pulses, tomatoes and tofu, exactly to your requirements.



Pet Foods...

Feed for our animals require the same standard of care and hygiene as that for food for human consumption. We can produce pumps with special hardened internals to handle everything from the raw ingredients such as chicken viscera and fats, to the finished gravies and sauces.



Personal Care Products...

Personal care products need a lot of personal care themselves. Many are very sensitive, some, like toothpastes are abrasive, others, like mascara are very, very thick and sticky. When we select a pump, we take personal care to ensure that it meets the needs of the customer.



Culinary Sauces...

We handle a wide variety of applications for all the major producers of culinary sauces. Finished cook-in sauces, condiment sauces such as mustard, horseradish and mint, through to apple and cranberry sauces. Selecting the correct pump at the right speed is most important otherwise delicate particulates can be damaged, emulsions cracked and product quality reduced.



Chocolate....

We know the importance of the gentle handling of finished chocolate, not to draw the temper, the requirements of low shear, and the need to maintain a constant temperature. Handled badly, the texture and taste of chocolate can easily change, chocolate needs a quality pump and a certain 'know-how'. Which fortunately, we have.



Pharmaceutical...

Most pharmaceutical applications require cleanliness, FDA approved materials and full material traceability. At Johnson Pump (UK) we can meet these requirements. All our product contact components are in 316L stainless steel, high standards of hygiene are assured with many of our pumps being EHEDG certified and all having 3A certification. So from inhalants to cough syrups, injectables to creams; Johnson Pump (UK) has a solution



Dairy Cream...

Hygiene is one of the most important factors in the dairy industry, so is the knowledge of product handling. Dairy creams require different handling solutions according to the fat content and pumping temperature. At Johnson Pump (UK), we know about cream, so when we pump your cream, you end up with high quality clean cream with the fats firmly still in solution.



Chemical and Industrial...

All our pumps have 316L (DIN1.4404) contact parts and are suitable for chemical applications. Should you need a more exotic alloy with superior chemical resistance.... we can deliver pumps in Hastelloy C22 and other materials, supply seals with Perfluorolastomer elastomers and ATEX compliant pumps with drive sets for the most stringent and hazardous environments.

Classic+ Technical specifications

Pump Performance Parameters

Model	Flow	Pressure	Port Ø	Max Speed
Classic	l/min	Bar	mm	RPM
CP10000212	0.046	12	25	1400
CP10000808	0.083	8	40	1400
CP10001105	0.111	5	40	1400
CP20002012	0.202	12	40	1000
CP20003107	0.312	7	50	1000
CP30006912	0.684	12	50	750
CP30011307	1.125	7	80	750
CP40018012	1.800	12	80	700
CP40025007	2.500	7	100	700
CP50035112	3.514	12	100	650
CP50052508	5.250	8	150	650

JOHNSON PUMP (UK)

products are used across the whole of the process industry in applications as diverse as paper and pulp production to the extremely hygienic end of the pharmaceutical and blood processing industry. We are the only dedicated lobe pump manufacturer to develop five distinct ranges of pumps for different industrial and niche applications. As a unit of the IDEX Corporation, we have access to a large and diverse range of engineered fluid handling equipment, all of the highest quality, all leaders in their field, with the expertise of application you would expect from a world class company.

A combination of the best of traditional engineering and innovative design together with the latest techniques in computer aided design, manufacture, testing and quality control ensure our entire range of pumps meet today's stringent demands for high product quality, reliability and affordability.



JOHNSON PUMP (UK)

Highfield Industrial Estate, Edison Road,
Eastbourne, East Sussex, BN23 6PT, ENGLAND
Phone: +44 1323 509211 • Fax: +44 1323 507306
E-Mail: jinfo@idexcorp.com • Web: www.johnsonpump.com

Kalrez® and Viton® are the registered trademarks of DuPont Performance Elastomers™.
Isolast® is the registered trademark of Bussak-Shamban. Johnson Pump (UK) reserve the right to alter specification without notice.



An Original Quality Product from
JOHNSON PUMP (UK)
classic+
Rotary Lobe Pump



Typical Applications

Food, Dairy, Beverages, Paper & Pulp, Chemicals,
Pharmaceuticals, Personal Care Products



Classic+. Hygienic in design, robust in construction

The Classic+ is a positive displacement rotary lobe pump designed using the latest innovative computer aided techniques and manufactured to meet today's stringent demands for high product quality, reliability, ease of maintenance, economy in purchase and low life time costs.

Superb operator and maintenance features, giving real operator benefits:

- Classic rotary lobe pump design
- Stainless steel 316L (DIN1.4404) contact parts
- Used throughout the whole of the process industry
- ATEX compliant
- Tri-lobe or multi-lobe rotor forms
- Flush rotor retention
- Hygienic flush front cover design
- Universal mounting with bolt on feet
- Easy to change shaft and port orientation
- Self draining when ports vertical.
- Low shear
- Externally mounted shaft seals
- Mechanical seals or simple 'O' ring seal
- Operates in either direction
- Standard 0.8µm Ra machine finish
- Enhanced surface finishes available
- Scratch resistant powder coated finish on CP10 – CP30
- Two pack epoxy finish on CP40 & CP50
- Protected front oil seals, prevents ingress of water from pressure washers
- Simpler to maintain

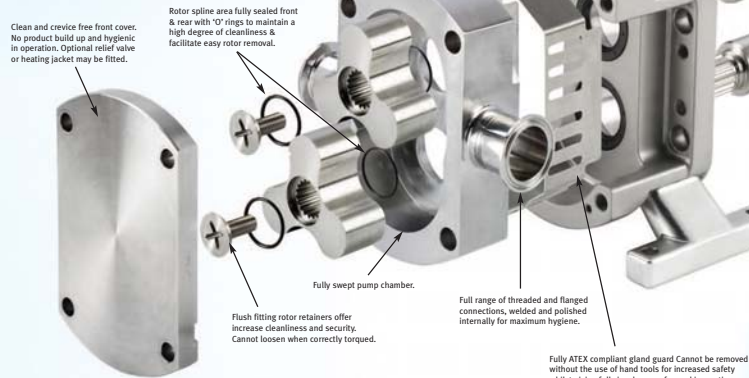

VERSITILITY AND SAFETY

For maximum flexibility, the feet of the pump may be removed and re-set to change the drive and port orientation to operate with the ports in a horizontal or a vertical position or to accommodate a top or bottom shaft drive. For heat sensitive applications, jackets may be fitted to the rotorcase and/or front cover to either heat or cool the pump head. To protect the pump, a spring operated relief valve may be fitted to the front cover. This can be set on site to protect the pump from over pressurisation and is available with air operation for automated CIP processes.

STAYS CLEANER

Hygienically designed, it combines a gentle pumping action for delicate liquids with soft solids as found in the food industry whilst robust, stainless steel construction is suited to the aggressive slurries and pastes of the chemical industry. For hygiene and corrosion resistance all product-wetted parts are manufactured from AISI 316L (DIN 1.4404) type stainless steel.

EASIER MAINTENANCE

The mechanical seals are of cartridge design with the rotary seal retention isolated from the pumped medium giving improved operation and easier assembly, setting and maintenance. Available in single, flushed or double seal configurations, all seal combinations use the same component wearing parts.

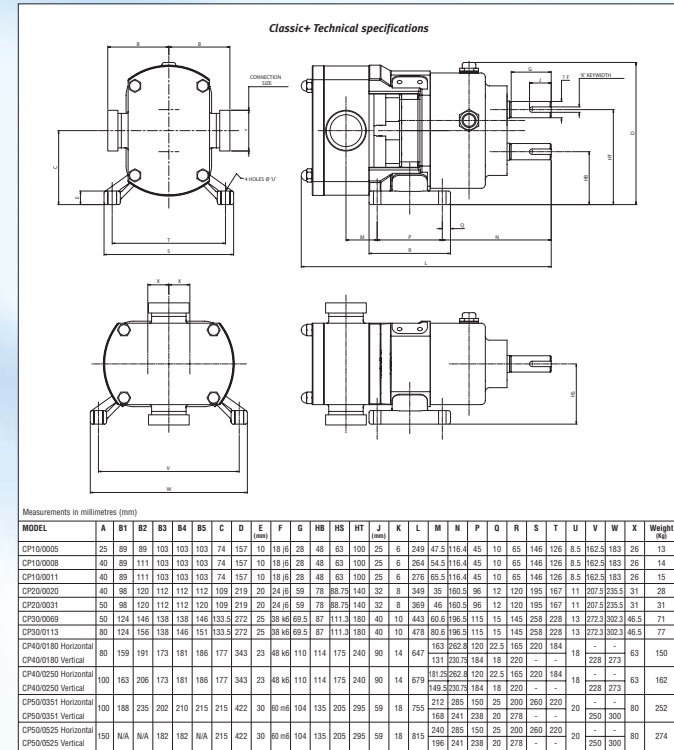

Classic+ pump technical specifications