



## 8" & 10" SELF-PRIMING CHOPPER PUMPS



- ✓ Largest Self-Priming Chopper
- ✓ Highest Efficiency - 70% BEP
- ✓ Highest Flow - 6000 GPM
- ✓ Highest Reprime - 22 Feet
- ✓ Heaviest Design - 3000 LB.
- ✓ Externally Adjustable Clearances
- ✓ Independent Casing & Housing
- ✓ Glass Lining Available
- ✓ Hardened Ductile Iron Available
- ✓ All Parts In-Stock

Model SP8N REPRIME LIFT	
RPM	LIFT (FT)
1185	22
1170	21
1065	20
970	19
930	18
885	15
860	14
785	12
740	11
700	10
650	9
615	8
500	7

CURVE	POWER (HP/KW)	SPEED (RPM)	IMPELLER DIAMETER
A	125/90	1185	16.00" (406 mm)
B	100/75	1170	16.00" (406 mm)
C	75/55	1065	16.00" (406 mm)
D	60/45	970	16.00" (406 mm)
E	50/37	930	16.00" (406 mm)
F	50/37	885	16.00" (406 mm)
G	40/30	860	16.00" (406 mm)
H	30/22	785	16.00" (406 mm)
I	25/18.5	740	16.00" (406 mm)
J	25/18.5	700	16.00" (406 mm)
K	20/15	650	16.00" (406 mm)
L	15/11	615	16.00" (406 mm)
M	15/11*	500	16.00" (406 mm)

Model SP10R REPRIME LIFT	
RPM	LIFT (FT)
1185	22
1150	21
1045	20
970	19
870	18
845	17
750	16
700	16
650	15
500	12

CURVE	POWER (HP/KW)	SPEED (RPM)	IMPELLER DIAMETER
A	125/90	1185	16.00" (406 mm)
B	100/75	1150	16.00" (406 mm)
C	75/55	1045	16.00" (406 mm)
D	60/45	970	16.00" (406 mm)
E	50/37	970	16.00" (406 mm)
F	40/30	845	16.00" (406 mm)
G	30/22	750	16.00" (406 mm)
H	25/18.5	700	16.00" (406 mm)
I	20/15	650	16.00" (406 mm)
J	15/11*	500	16.00" (406 mm)

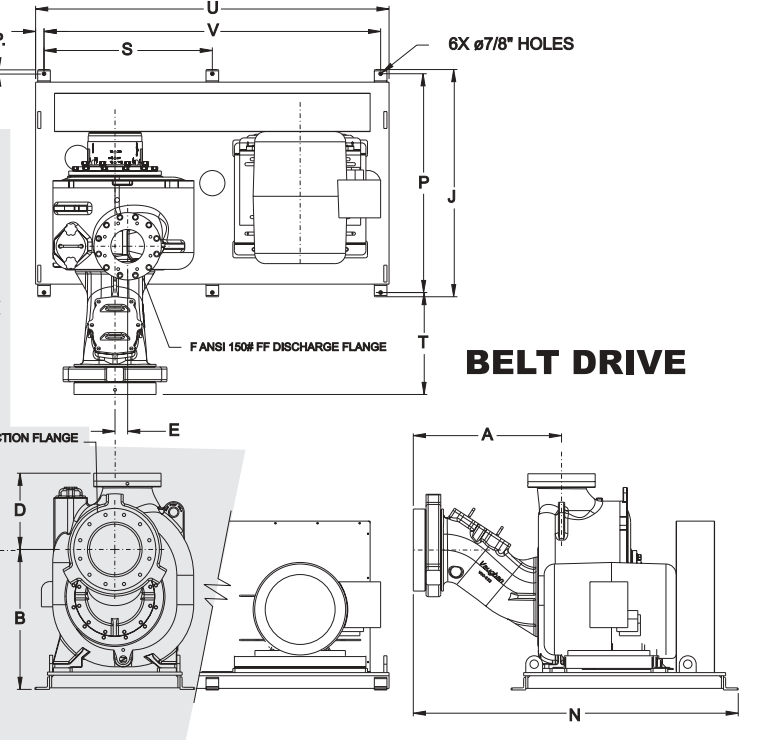
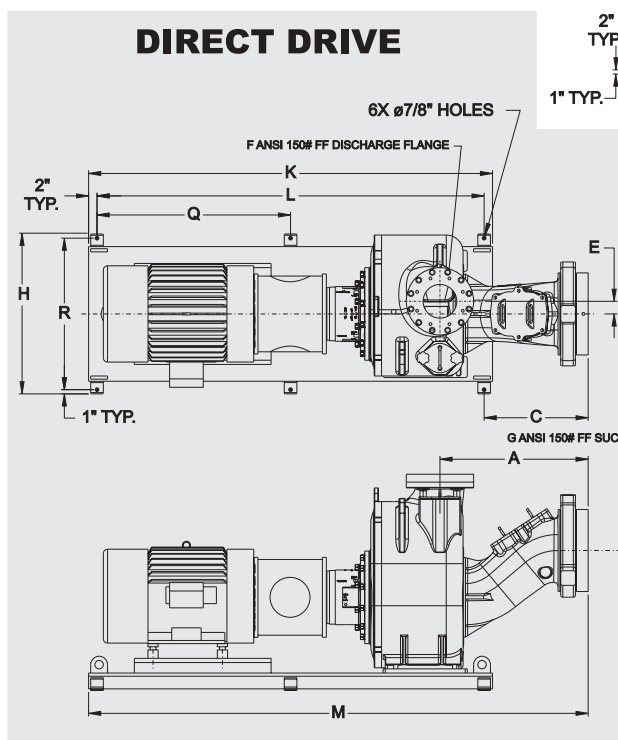
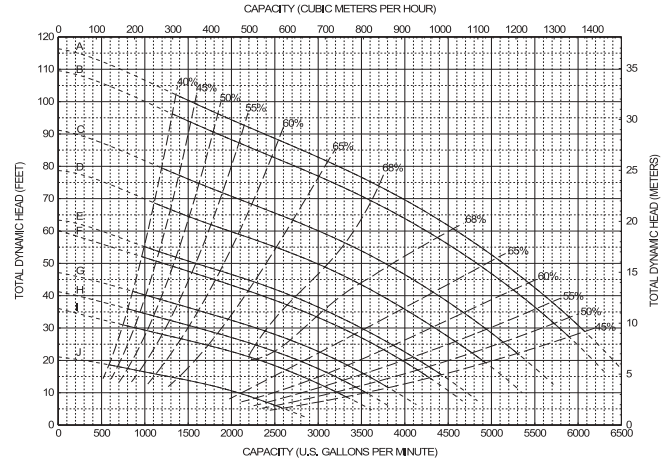
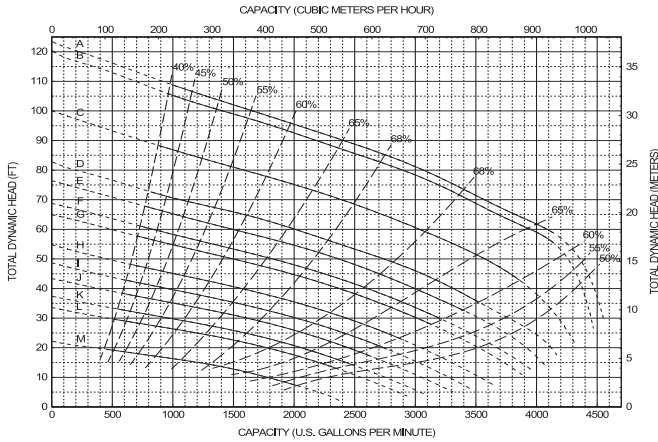

DIRECT DRIVE

MODEL	A	B	C	D	E	F	G
SP8N	35 1/4	33 1/4	24 3/4	16 1/4	3	8	10
SP10R	35 1/4	33 1/4	24 3/4	18 1/8	3	10	12

MODEL	H	K	L	M	Q	R
SP8N	38 3/16	96	92	118 3/4	46	36
SP10R	38 3/16	96	91	118 3/4	46	36

BELT DRIVE

MODEL	A	B	D	E	F	G	J
SP8NB	35 1/4	33 1/4	16 1/4	3	8	10	54
SP10RB	35 1/4	33 1/4	18 1/8	3	10	12	54

MODEL	N	P	S	T	U	V
SP8NB	77 1/4	52	40	24 1/4	84	80
SP10RB	77 1/4	52	40	24 1/4	84	80

## Vaughan Co., Inc.

364 Monte Elma Road, Montesano, WA 98563

Phone: (360)249-4042, FAX: (360)249-6155

Toll Free: (888)249-CHOP

www.chopperpumps.com

e-mail: info@chopperpumps.com